

SELLEYS®

IF IT'S SELLEYS IT WORKS™



SELLEYS S21 AIRLESS SPRAYPACK
SELLEYS S21 HI-BOY SPRAYPACK

OPERATING MANUAL

CONTENTS

1. SAFETY INFORMATION

- 1.1 General Safety Precautions
- 1.2 Specific Safety Hazards and Precautions
- 1.3 Earthing Instructions

2. COATINGS

- 2.1 Suitable Coatings
- 2.2 Preparation of Coating Materials
- 2.3 Viscosity
- 2.4 Coatings Containing Abrasive Materials

3. EQUIPMENT

- 3.1 Technical Data
- 3.2 Main Components

4. OPERATING INSTRUCTIONS

- 4.1 Starting Up
- 4.2 Control Panel Indicators
- 4.3 Connection to the Mains Network
- 4.4 Flushing of Preserving Agent Before Starting Up
- 4.5 Before Spraying the Coating Material
- 4.6 Method of Spraying
- 4.7 Handling the High-Pressure Hose
- 4.8 In Case of Interrupted Operation

5. CLEANING AND MAINTENANCE

- 5.1 Cleaning and Shutting Down
- 5.2 Cleaning the Suction Filter
- 5.3 Cleaning the High-Pressure Filter
- 5.4 Cleaning the Airless Spray Gun
- 5.5 Disassembly of the Intake Filter
- 5.6 Assembly of the Intake Filter

6. MALFUNCTIONS

- 6.1 Corrective Measures for Common Malfunctions
- 6.2 Error Codes

7. SERVICING AND REPAIRS

- 7.1 Routine Checking
- 7.2 Repairs to the Relief Valve
- 7.3 Repairs to the Inlet and Outlet Valve
- 7.4 Repairs to the Packings

8. CONNECTION GUIDE

9. PARTS AND ASSEMBLY

1. SAFETY INFORMATION

Please read the following important information carefully.

The following symbols indicate specific types of safety hazards.



Indicates a potential hazard that may cause **serious injury to the operator or loss of life.**



Indicates a potential hazard that may cause **minor injury to the operator or to the equipment.**



Indicates **important information.**



WARNING

This unit is capable of extremely high spraying pressures that can cause serious and/or minor injury by injection and extensive damage to property.



IMPORTANT

All replacement parts and accessories should **ONLY** be purchased from SELLEYS or an authorised distributor of SELLEYS equipment. Servicing should **ONLY** be carried out by SELLEYS or an authorised distributor of SELLEYS equipment. If these conditions are not met, the operator assumes all liability for injury and property damage arising from the use of this unit.

1.1 GENERAL SAFETY PRECAUTIONS

✘ NEVER

- use the spray gun without the safety guard in place
- operate faulty units or use faulty accessories
- attempt to repair a damaged hose
- leave this equipment unattended
- move the unit when it is running
- spray outside on windy days

✔ ALWAYS

- ensure that this unit is properly earthed
- ensure that the power cord, air hose and spray hoses are optimally routed to minimise slip, trip and fall hazards
- immediately and thoroughly clean up all material and solvent spills to prevent slip hazards
- follow the material manufacturer's instructions for safe handling of coating materials
- unplug the cord from the outlet before cleaning, maintaining or repairing this unit
- keep the power cord plug in sight during use to prevent accidental shutdowns and startups
- wear ear protection to protect against possible hearing loss from the noise produced by this unit, which can exceed 85 dB(A)
- keep this unit out of reach of children, unqualified adults and animals
- comply with local codes regarding ventilation, fire prevention, and operation

1.2 SPECIFIC SAFETY HAZARDS AND PRECAUTIONS

SAFETY HAZARD: INJECTION INJURY



WARNING

Serious risk of injection injury. This equipment produces a high-pressure stream that can pierce the skin and subcutaneous tissues, resulting in severe injury and even possible amputation.



IMPORTANT

The maximum operating range of the unit is 220 bar (3200 PSI) fluid pressure.

✘ NEVER

- put your fingers, hands or any other parts of your body into the spray jet
- point the spray gun at yourself or anyone else (including animals)
- allow the fluid stream to come into contact with any part of your body
- allow any leak in the fluid hose to come into contact with any part of your body
- put your hand in front of the gun

NOTE: Gloves do not provide full protection against injection injury.

✔ ALWAYS

- ensure that the gun trigger is locked, the fluid pump is shut off, and all pressure is released before servicing, cleaning the nozzle holder, changing spray tip, or leaving the unit unattended

NOTE: Turning off the engine will not release the pressure. The PRIME/SPRAY valve or pressure bleed valve must be turned to their appropriate positions to relieve system pressure.

- ensure that the nozzle holder remains in place during spraying
- remove the spray tip before flushing or cleaning the system
- carefully check the paint hose for leaks before each use, as even small leaks can cause injection injury
- ensure that all accessories, including but not limited to spray tips, guns, extensions and hose, are rated at or above the maximum operating pressure range of the sprayer



IMPORTANT MEDICAL INFORMATION

Injection injury is a traumatic injury that requires immediate medical attention. Any laceration of the skin, no matter how minor it seems, should not be treated as a simple cut. Fully inform the medical team about the coatings or solvents involved, as some coatings are toxic when injected directly into the bloodstream. For serious injuries, a plastic surgeon or reconstructive hand surgeon should be consulted.

SAFETY PRECAUTIONS TO PREVENT EXPLOSIONS AND FIRE



WARNING

This equipment produces a high-pressure stream that can pierce the skin and subcutaneous tissues, resulting in severe injury and even possible amputation.

✗ NEVER

- use plastic drop cloths or enclose the spray area with plastic sheets, as plastic can cause static sparks
- smoke in the spray area
- use any materials with a flashpoint lower than 21 °C (70 °F)

NOTE: Flashpoint is the temperature at which a fluid can produce sufficient vapours to ignite.

✓ ALWAYS

- ensure that the spray area is well-ventilated to prevent the build-up of flammable vapours
- avoid all ignition sources such as static electricity sparks, electrical appliances, flames, pilot lights, hot objects, and sparks from connecting and disconnecting power cords and/or working light switches
- flush the unit into a separate metal container, at the lowest possible pump pressure and with the spray tip removed
- hold the gun firmly against the side of the container to prevent static sparks
- have a fire extinguisher nearby
- place the sprayer at a minimum of 6.1 metres (20 feet) from the surface to be sprayed, extending the hose if necessary. Since flammable vapours are often heavier than air, the floor area must be well ventilated. The pump contains arcing parts that emit sparks, which can ignite vapours.
- ensure that the equipment and objects in and around the spray area are properly grounded to prevent static sparks
- ensure that you are using a conductive or earthed high pressure hose
- ensure that the gun is earthed through the hose connection
- ensure that the power cord is connected to a grounded circuit
- ensure that the unit is connected to an earthed object such as a water pipe, steel beam, or other electrically earthed surface, via the green earthing wire
- strictly follow the material and solvent manufacturer's warnings and instructions, and read the coating material's MSDS (Material Safety Data Sheet) and technical information before use

SAFETY PRECAUTIONS TO PREVENT EXPLOSIONS DUE TO INCOMPATIBLE MATERIALS



WARNING

Serious risk of explosions due to incompatible materials. Accidental explosions due to incompatible materials can cause serious injury and/or extensive damage to property.

✗ NEVER

- use materials that contain bleach or chlorine
- use halogenated hydrocarbon solvents such as methylene chloride and 1,1,1-trichloroethane

NOTE: These substances are not compatible with aluminium and may cause an explosion. If you are in any doubt over a material's compatibility with aluminium, check with your coating supplier.

SAFETY PRECAUTIONS TO PREVENT HARM FROM TOXIC VAPOURS



WARNING

Vapours from paints, solvents, insecticides, and other materials can be harmful in the event of inhalation or contact with any part of the body. Symptoms include severe nausea, fainting and poisoning.

✓ ALWAYS

- use a respirator or mask
- wear protective eyewear
- wear protective clothing

1.3 EARTHING INSTRUCTIONS

✗ NEVER

- operate this unit unless you are sure that it has been properly earthed
- modify the earthing plug

✓ ALWAYS

- ensure that the earthing plug is plugged into an outlet that has been properly installed and earthed in accordance with local codes
- seek the advice of a qualified electrician if you need a new outlet installed to fit the earthing plug, do not fully understand these earthing instructions, or are unsure as to whether this unit is properly earthed



WARNING

Incorrect installation of the earthing plug can result in electric shock. If you need to repair or replace the cord or plug, do not connect the green earthing wire to either blade terminal.



IMPORTANT

The wire with insulation, which has a green outer surface with or without yellow stripes, is the earthing wire. It must be connected to the earthing pin.

A list of the materials used in the construction of this unit is available upon request for the purpose of determining compatibility with coating materials.

2. COATINGS

Read the following important information carefully.

2.1 SUITABLE COATINGS

This unit is suitable for the application of:

- dilutable lacquers and paints
- coatings containing solvents
- dispersions
- latex paints

Do not spray coatings other than those listed above without the prior approval of SELLEYS or the authorised distributor of this unit.

2.2 PREPARATION OF COATING MATERIALS

Always filter and stir the coating material before application. To prevent downtime, make sure that no air bubbles are introduced, especially when stirring the coating material with motor-driven agitators.

2.3 VISCOSITY

This unit is able to process highly viscous coating materials of up to around 20,000 mPa-s.

Highly viscous coating materials can be diluted according to the manufacturer's instructions.

2.4 COATINGS CONTAINING ABRASIVE MATERIALS

Coatings that contain sharp-edged aggregates and additional materials cause intense wear and tear on this unit's parts, including its valves, high-pressure hose, spray gun and spray tip.

Use of abrasive coatings may shorten the working life of this unit.

3. EQUIPMENT

Please read the following important information carefully.

3.1 TECHNICAL DATA

Voltage	220 V / 50 Hz
Motor output	1.1 kW
Max. operating pressure	220 bar
Flow rate	2.3 L/min
Max. nozzle size	0.021"
Max. temperature of the coating material	43 °C
Max. viscosity	20,000 mPa-s
Weight	17 kg
High pressure hose	DN 6 mm, 15 m
Dimensions (L x W x H)	440 x 370 x 420 mm
Max. sound pressure level	80 dB

3.2 MAIN COMPONENTS

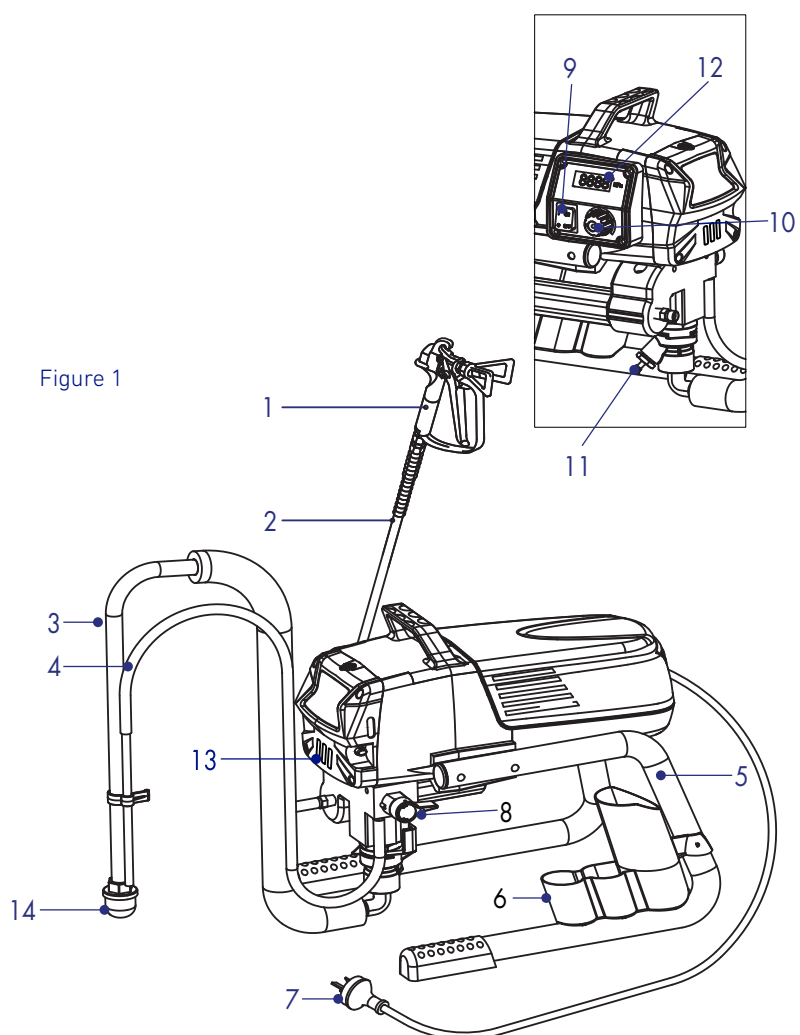

NO.	NAME
1	Spray gun
2	High-pressure hose
3	Suction hose
4	Return hose
5	Frame
6	Drip cup
7	Power cord

NO.	NAME
8	Relief valve
9	ON/OFF switch
10	Pressure control knob
11	Pressure stem
12	Manometer indicator
13	Oil reservoir
14	Suction filter

4. OPERATING INSTRUCTIONS

Please read the following important information carefully.

4.1 STARTING UP

Follow these steps carefully.

1. Screw the high-pressure hose to the coating material outlet
2. Screw the spray gun with the selected spray tip onto the high-pressure hose
3. Tighten the union nuts at the high-pressure hoses to prevent coating from leaking
4. Drip a few drops of the lubricating oil into the oil reservoir

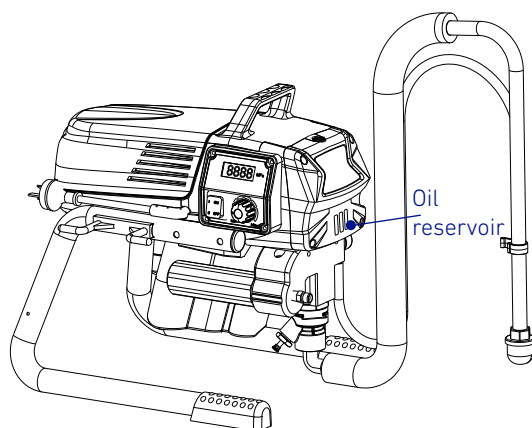

5. Fully depress the pressure stem to ensure that the inlet ball is free

4.2 CONTROL PANEL INDICATORS

The following diagrams depict the control panel indicators. Set the pressure control knob to the required pressure to start work. Turn clockwise to increase pressure, and counter-clockwise to decrease pressure.

Figure 2: Pulsating pressure for cleaning zone

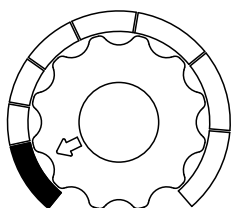
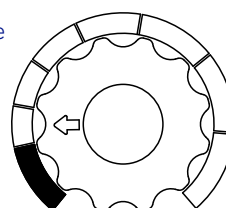

Figure 3: The minimum pressure is increasing clockwise



4.3 CONNECTION TO THE MAINS NETWORK

Electrical System: 220 VAC / 50 Hz

The unit must be connected to a securely grounded safety outlet.

Before connecting the unit to the mains supply, ensure that the line voltage complies with the specification on the unit's rating plate.

4.4 FLUSHING OF PRESERVING AGENT BEFORE STARTING UP

Follow these steps carefully.

1. Immerse the suction hose (Figure 4.1) and return hose (4.2) in a container with a suitable cleaning agent
2. Turn the pressure control knob (4.5) counter-clockwise to minimum pressure
3. Open the relief valve (4.3) and set it to PRIME (Figure 5)
4. Switch the unit ON (4.4)
5. Wait until the cleaning agent discharges from the return hose
6. Turn the relief valve (4.3) and set it to SPRAY (Figure 6)
7. Pull the trigger of the spray gun
8. Spray the cleaning agent from the unit into an open container

Figure 4

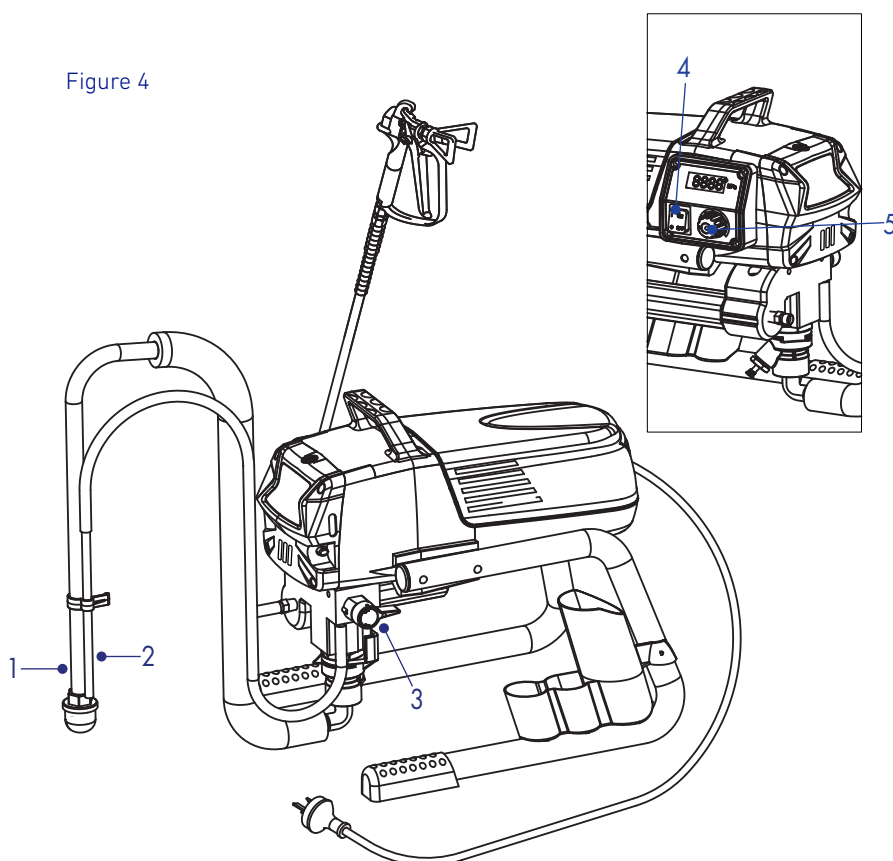

Figure 5

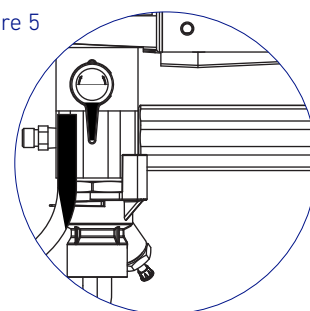
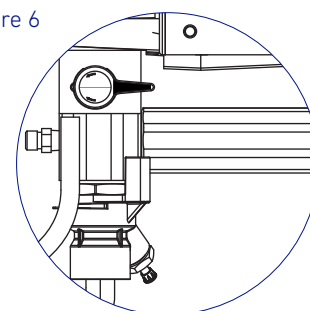

Figure 6



4.5 BEFORE SPRAYING THE COATING MATERIAL

Follow these steps carefully.

1. Immerse the suction hose (Figure 4.1) and return hose (4.2) in the coating material container
2. Turn the pressure control knob (4.5) counter-clockwise to minimum pressure
3. Open the relief valve (4.3) and set it to PRIME (Figure 5)
4. Switch the unit ON (4.4)
5. Wait until the coating material discharges from the return hose
6. Turn the relief valve (4.3) and set it to SPRAY (Figure 6)
7. Trigger the spray gun several times and spray into a container until the coating material exits the spray gun
8. Increase the pressure by slowly turning the pressure control knob (4.5) clockwise
9. Check the spray pattern and increase the pressure until the desired atomisation is attained
10. The unit is ready to spray

4.6 METHOD OF SPRAYING



WARNING

Never trigger the gun unless the spray tip is completely turned to either the spray or the unclog position. Always engage the gun trigger lock before removing, replacing or cleaning the spray tip.

Follow these steps carefully.

1. Ensure that the nozzle holder is in place
2. Trigger the gun AFTER starting the stroke
3. To ensure even application:
 - keep your arm moving at a constant speed
 - keep the spray gun perpendicular to the surface
 - keep the spray gun at a constant distance of 25 to 30 cm from the surface
 - overlap each stroke by about 30%

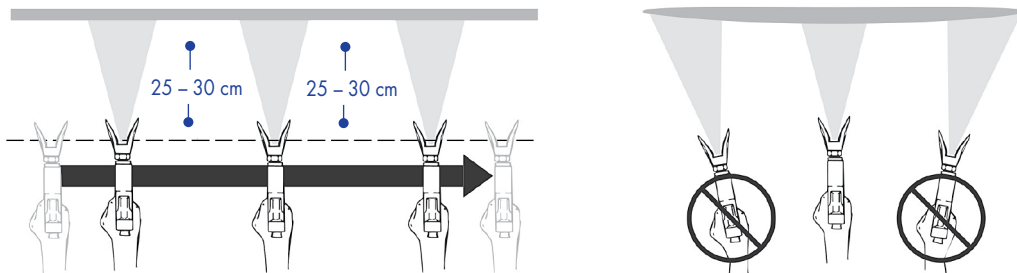

4. Release the gun BEFORE ending the stroke



IMPORTANT

If very sharp edges or streaks appear on the coated surface, increase the operating pressure or dilute the coating material.

4.7 HANDLING THE HIGH-PRESSURE HOSE

Avoid sharp bending or kinking of the high-pressure hose. The smallest bending radius amounts to about 20 cm.

Do not drive over the high-pressure hose, and avoid contact with sharp objects and edges.



WARNING

Defective high-pressure hoses can leak and cause serious injection injury. Replace defective high-pressure hoses immediately. Never attempt to repair a defective high-pressure hose.

4.8 IN CASE OF INTERRUPTED OPERATION

Follow these steps carefully.

1. Open the relief valve (Figure 4.3) and set it to PRIME (Figure 5)
2. Switch the unit OFF (4.4)
3. Turn the pressure control knob (4.5) counter-clockwise to minimum pressure

4. Pull the trigger of the spray gun in order to release the pressure from the high-pressure hose and spray gun
5. Secure the spray gun
6. Leave the suction tube (or the suction hose and return hose) immersed in the coating material, or swivel or immerse it in a suitable cleaning agent



IMPORTANT

If a fast-drying or two-component coating material is used, ensure that the unit is rinsed with a suitable cleaning agent within the processing time.

5. CLEANING AND MAINTENANCE

Please read the following important information carefully.

5.1 CLEANING AND SHUTTING DOWN

CLEANING THIS UNIT

1. Clean and remove the spray tip

NOTE: If using a non-standard spray tip, refer to the relevant Operating Manual for cleaning instructions.

2. Remove the suction hose (Figure 4.1) from the coating material
3. Close the relief valve (4.3) and set it to SPRAY (Figure 6)
4. Switch the unit ON (4.4)
5. Pull the trigger of the spray gun and pump the remaining coating material from the suction hose, high-pressure hose and spray gun into an open container



WARNING

The container must be earthed in case of coating materials that contain solvents. Do not pump or spray unused coating material into a container with a small opening (bunghole).

6. Immerse the suction hose with return hose in a container with a sufficient amount of a suitable cleaning agent

NOTE: Cleaning agent's ignition point must exceed 21 °C.

7. Turn the pressure control knob (4.5) into the blue zone-pulsating pressure for unit cleaning (Figure 2)
8. Open the relief valve (4.3) and set it to PRIME (Figure 5)
9. Pump a suitable cleaning agent in the circuit for a few minutes
10. Pour any remaining cleaning agent into an open container until the unit is empty
11. Switch the unit OFF (4.4)

5.2 CLEANING THE SUCTION FILTER

Follow these steps carefully to ensure optimal feed, constant spraying pressure and smooth operation.

1. Unscrew the suction filter (Figure 7.1) from the suction hose
2. Clean the suction filter with a hard brush and a sufficient amount of a suitable cleaning agent

Figure 7

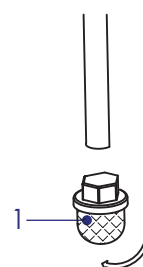

IMPORTANT

Replace the suction filter if it is clogged or faulty.

5.3 CLEANING THE HIGH-PRESSURE FILTER

Follow these steps carefully.

1. Turn the pressure control knob (Figure 4.5) counter-clockwise to minimum pressure
2. Open the relief valve (4.3) and set it to PRIME (Figure 5)
3. Switch the unit OFF (4.4)



WARNING

Always unplug the power plug from the outlet.

4. Unscrew the filter housing (Figure 8.1) with a strap wrench
5. Pull the filter cartridge (8.2) from the bearing spring (8.3)
6. Clean all parts with a sufficient amount of a suitable cleaning agent
7. Check the O-ring (8.4) and replace it if necessary
8. Place the bearing ring (8.5) against the bearing spring (8.3). Slide the filter cartridge (8.2) over the bearing spring.
9. Open the relief valve (4.3) and set it to PRIME (Figure 5)



IMPORTANT

The container must be earthed in case of coating materials that contain solvents.

Figure 8

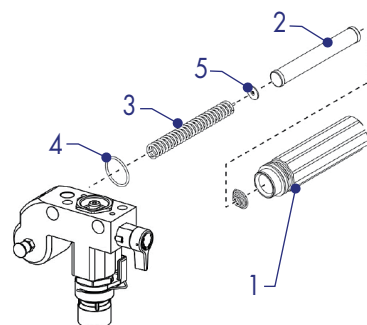

5.4 CLEANING THE AIRLESS SPRAY GUN

Follow these steps carefully.

1. Rinse the airless spray gun with a sufficient amount of a suitable cleaning agent
2. Thoroughly clean the spray tip with a sufficient amount of a suitable cleaning agent until all unused coating material has been removed
3. Thoroughly clean the outside of the airless spray gun

5.5 DISASSEMBLY OF THE INTAKE FILTER

Follow these steps carefully.

1. Pull the protective guard (Figure 9.1) forward with moderate force
2. Unscrew the grip (9.2) from the gun housing and remove the intake filter (9.3)



IMPORTANT

Replace the intake filter if it is clogged or faulty.

Figure 9

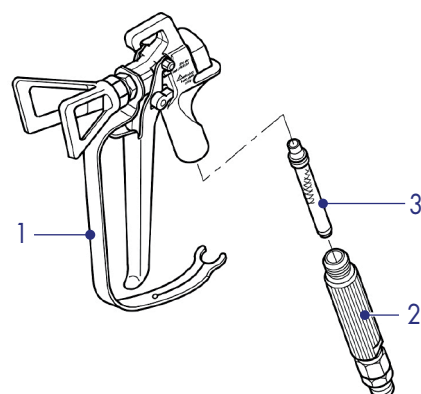

5.6 ASSEMBLY OF THE INTAKE FILTER

Follow these steps carefully.

1. Place the intake filter (Figure 9.3) with the long cone into the gun housing
2. Screw the grip (9.2) into the gun housing and tighten
3. Slot in the protective guard (9.1)

6. MALFUNCTIONS

Refer to the chart below for instructions on how to correct common malfunctions.

6.1 CORRECTIVE MEASURES FOR COMMON MALFUNCTIONS

TYPE OF MALFUNCTION	POSSIBLE CAUSES	CORRECTIVE MEASURES
A. Unit does not start	<ol style="list-style-type: none"> 1. No voltage applied 2. Pressure setting is too low 3. ON/OFF switch is defective 	<ol style="list-style-type: none"> 1. Check voltage supply 2. Turn up pressure control knob 3. Replace
B. Unit does not draw in material	<ol style="list-style-type: none"> 1. Relief valve is set to SPRAY 2. Filter projects over the fluid level and sucks air 3. Filter is clogged 4. Suction hose/suction tube is loose, i.e. the unit is sucking in outside air 	<ol style="list-style-type: none"> 1. Set relief valve to PRIME (circulation) 2. Refill the coating material 3. Clean or replace the filter 4. Clean connecting points. Replace O-rings if necessary. Secure suction hose with retaining clip.
C. Unit draws in material, but the pressure does not build up	<ol style="list-style-type: none"> 1. Spray tip is heavily worn 2. Spray tip is too large 3. Pressure setting is too low 4. Filter is clogged 5. Coating material flows through the return hose when the relief valve is in the SPRAY position 6. Packings are sticky or worn 7. Valve balls are worn 8. Valve seats are worn 	<ol style="list-style-type: none"> 1. Replace 2. Select a smaller spray tip 3. Turn pressure control knob clockwise to increase pressure 4. Clean or replace the filter 5. Remove and clean or replace relief valve 6. Remove and clean or replace packings 7. Remove and replace valve balls 8. Remove and replace valve seats
D. Coating material exits at the top of the fluid section	<ol style="list-style-type: none"> 1. Upper packing is worn 2. Piston is worn 3. Incorrect high-pressure hose type 	<ol style="list-style-type: none"> 1. Remove and replace packing 2. Remove and replace piston 3. Only use original high-pressure hoses
E. Increased pulsation at the spray gun	<ol style="list-style-type: none"> 1. Incorrect high-pressure hose type 2. Spray tip is worn or too large 3. Pressure is too high 	<ol style="list-style-type: none"> 1. Only use original-high pressure hoses 2. Replace spray tip 3. Turn pressure control knob to a lower number
F. Poor spray pattern	<ol style="list-style-type: none"> 1. Spray tip is too large for the coating material being sprayed 2. Pressure setting is incorrect 3. Volume is too low 4. Coating material viscosity is too high 	<ol style="list-style-type: none"> 1. Replace spray tip 2. Turn pressure control knob until a satisfactory spraying pattern is achieved 3. Clean or replace all filters 4. Thin out according to the manufacturer's instructions
G. Unit loses power	<ol style="list-style-type: none"> 1. Pressure setting is too low 	<ol style="list-style-type: none"> 1. Turn pressure control knob clockwise to increase

6.2 ERROR CODES

ERROR CODE	ERROR DESCRIPTION	CONDITIONS	MAINTENANCE ADVICE
ERR_1	Hardware overcurrent protection	Hardware overcurrent circuit signal is detected	<ol style="list-style-type: none"> 1. Switch power OFF and ON 2. Replace circuit board 3. Replace electric motor
ERR_2	Software detects that the motor current is high	The software detects the motor current is high	<ol style="list-style-type: none"> 1. Switch power OFF and ON 2. Replace circuit board 3. Replace electric motor
ERR_3	Bus-bar voltage is high	The input voltage is high	<ol style="list-style-type: none"> 1. Check that input voltage is not more than 260 VAC 2. Replace circuit board
ERR_4	Bus-bar voltage is low	The input voltage is low	<ol style="list-style-type: none"> 1. This feature is temporarily disabled
ERR_5	Abnormal motor hall	The three halls of the motor appear at high level or low level	<ol style="list-style-type: none"> 1. Check that the hall terminal is tightly fitted into the circuit board 2. Replace circuit board 3. Replace electric motor
ERR_9	Chip memory error alarm	An error occurred while data is stored in the chip	<ol style="list-style-type: none"> 1. Replace circuit board
ERR_10	Motor current amplifier error	The internal operational amplifier circuit is abnormal when the motor is not running	<ol style="list-style-type: none"> 1. Replace circuit board
ERR_11	High pressure error	The output circuit voltage of the pressure sensor is high	<ol style="list-style-type: none"> 1. Reduce pressure
ERR_12	The motor is protected when the equipment has no pressure	A protection mechanism when the motor is running continuously for one minute during return phase	<ol style="list-style-type: none"> 1. Switch power OFF and ON
ERR_13	Chip ID error	Abnormality was detected after powering ON	<ol style="list-style-type: none"> 1. Replace circuit board
ERR_14	Starter motor stall protection	The motor is blocked or not running	<ol style="list-style-type: none"> 1. Check that the UVW connection of the motor is intact 2. Replace circuit board 3. Replace electric motor
ERR_15	Pressure sensor failure	Detected abnormal signal of pressure sensor	<ol style="list-style-type: none"> 1. Check that the pressure sensor is well connected 2. Replace pressure sensor 3. Replace circuit board
ERR_16	Communication check code error	The chip indicated a checksum error during internal communication	<ol style="list-style-type: none"> 1. Replace circuit board
ERR_17	Abnormal pressure feedback	The pressure estimated by the software differs from the actual pressure	<ol style="list-style-type: none"> 1. Check that the pressure sensor is well connected 2. Replace pressure sensor 3. Replace circuit board
ERR_18	Communication failure	No communication signal is received in the chip	<ol style="list-style-type: none"> 1. Replace circuit board

7. SERVICING AND REPAIRS

Please read the following important information carefully.

Repairs to the Relief Valve (Section 7.2), Inlet and Outlet Valve (Section 7.3), and Packings (Section 7.4) should only be carried out by a qualified electrician or an authorised distributor of SELLEYS equipment.

Remember to get this unit serviced annually (or more often in the case of heavy usage) by an authorised distributor of SELLEYS equipment.



WARNING

Always unplug the power plug from the outlet before commencing any repair works on the unit.

7.1 ROUTINE CHECKING

Prior to every use/on a weekly basis:

- check the high-pressure hoses and the device connecting the line and plug for damage and wear
- check the inlet valve, outlet valve and filter for damage and wear
- check the high-pressure hose for any notches or bulges, especially around the transitions in the fittings. You should be able to easily turn the union nuts, without using force.

7.2 REPAIRS TO THE RELIEF VALVE

Follow these steps carefully.

1. Use a drift punch of 2 mm to remove the grooved pin (Figure 10.1) from the relief valve (10.2)
2. Remove the relief valve (10.2) and cam base (10.3)
3. Remove the valve housing (10.4) from the pump assembly (10.6) with a wrench
4. Ensure that the seal (10.5) is seated correctly, then screw the new valve housing (10.4) completely into the pump assembly (10.6) and tighten with a wrench
5. Align the cam base (10.3) with the hole in the pump assembly (10.6). Lubricate the cam base with grease and slide on the cam base.
6. Align the hole in the valve shaft (10.7) with the hole in the relief valve (10.2)

Figure 10

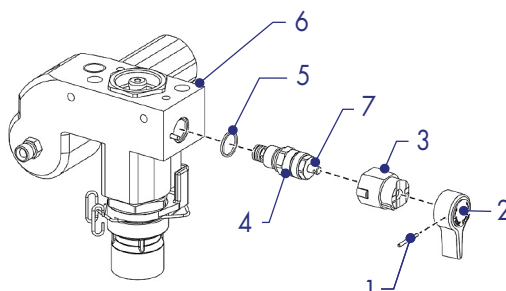

7.3 REPAIRS TO THE INLET AND OUTLET VALVE

Follow these steps carefully.

1. Remove the four screws in the front cover and remove the front cover
2. Switch the unit ON and then OFF so that the piston rod is positioned in the lower stroke position



WARNING

To avoid crushing injury, never reach into moving parts with fingers or tools.

3. Unplug the power plug from the outlet
4. Remove the retaining clip from the connecting bend at the suction hose and pull off the suction hose
5. Unscrew the return hose
6. Swivel the unit 90° to the rear in order to comfortably access the material feed pump
7. Remove the pressure stem clip and slide the pressure stem housing (Figure 11.7) from the inlet valve housing (11.1)
8. Unscrew the inlet valve housing (11.1) from the pump manifold
9. Remove the lower seal (11.2), lower ball guide (11.3), inlet valve ball (11.4), inlet valve seat (11.5) and O-ring (11.6)
10. Clean all the parts with an appropriate cleaning agent

Figure 11

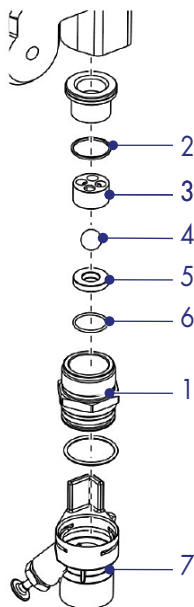
**IMPORTANT**

Check the inlet valve housing (Figure 11.1), inlet valve seat (11.5) and inlet valve ball (11.4) for wear and replace them if necessary. If the worn inlet valve seat (11.5) is unused on one side, remove it and reinstall it the other way round.

11. Unscrew outlet valve housing (Figure 12.8) from the piston (12.9) with adjusting wrench
12. Check the inlet valve housing (Figure 11.1), inlet valve seat (11.5) and inlet valve ball (11.4) for wear and replace the parts if necessary
13. Remove the upper ball cage (Figure 12.11), washer (12.10), outlet valve ball (12.12), and outlet valve seat (12.13)
14. Install parts in the reverse order, lubricating the O-ring (Figure 11.6) with grease and ensuring proper seating in the inlet valve housing (11.1)

Figure 12

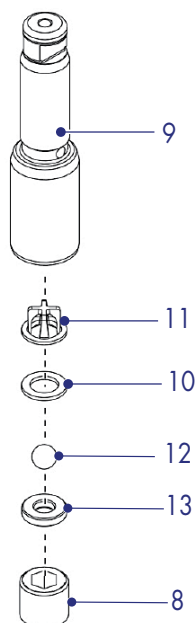

7.4 REPAIRS TO PACKINGS

Follow these steps carefully.

1. Remove the inlet valve housing according to the instructions outlined in Section 7.3 of this Operating Manual
2. Unscrew both cylinder head screws (Figure 13.1) from the pump assembly (13.2) with a 3/8-inch hexagon socket head wrench
3. Slide the pump assembly (13.2) and piston (13.3) forward until the piston is out of the T-slot (13.9) on the slider assembly (13.4)
4. Push the piston (13.3) downward out of the pump assembly (13.2)
5. Unscrew the retainer nut (13.5) from the pump assembly (13.2) and remove the piston guide (13.6)
6. Remove the upper packing (13.7) and lower packing (13.8) from the pump

Figure 13

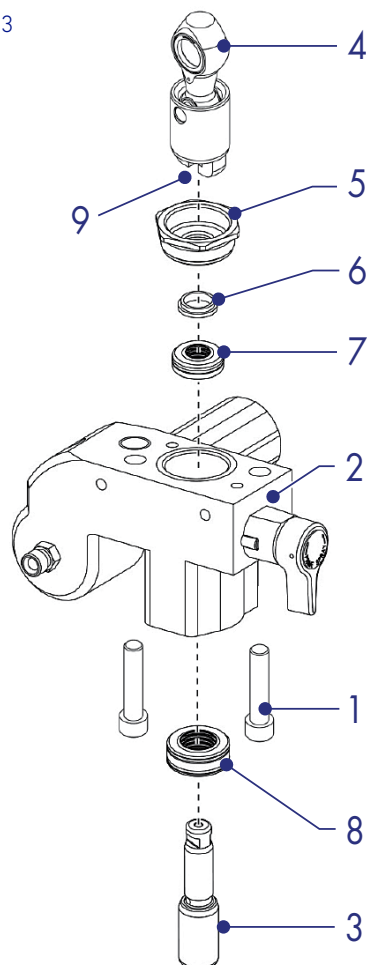

Figure 14

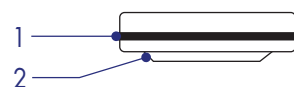
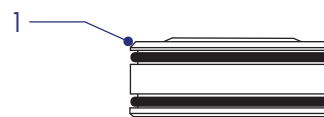

Figure 15



7. Clean the pump assembly (13.2)
8. Lubricate the upper packing (13.7) and lower packing (13.8) with grease
9. Insert the upper packing with O-ring (Figure 14.1) and protruding lip (14.2) downward
10. Insert the lower packing with the bevelled edge (Figure 15.1) facing upward
11. Insert the piston guide (Figure 13.6) into the retainer nut (13.5)
12. Screw the retainer nut (13.5) into the pump assembly (13.2) and tighten by hand
13. Push the installation tool (included with the replacement packings) for the piston (13.3) from above onto the piston
14. Lubricate the installation tool and piston (13.3) with grease

15. Guide the piston (13.3) through the lower packings (13.8) into the pump assembly (13.2) from below
16. Using a rubber mallet, lightly tap the piston (13.3) from below until it can be seen above the pump assembly
17. Remove the installation tool from the piston (13.3)
18. Carefully tighten the retainer nut (13.5) with an adjusting wrench
19. Slide the top of the piston (13.3) into the T-slot (13.9) on the slider assembly (13.4)
20. Position the pump assembly (13.2) underneath the gear unit housing and push up until it rests against the gear unit housing
21. Screw the pump assembly (13.2) to the gear unit housing
22. Lubricate the O-ring (Figure 11.6) between the pump assembly (11.2) and the inlet valve housing with machine grease the pump manifold
23. Screw the inlet valve housing to the pump assembly
24. Insert the elbow on the siphon assembly into the button of the pusher stem housing
25. Push the retaining clip up into the groove inside the foot valve housing to secure the siphon assembly in position
26. Place the return tube over the return tube fitting and secure with the clip the gear unit housing
27. Install the front cover

8. CONNECTION GUIDE

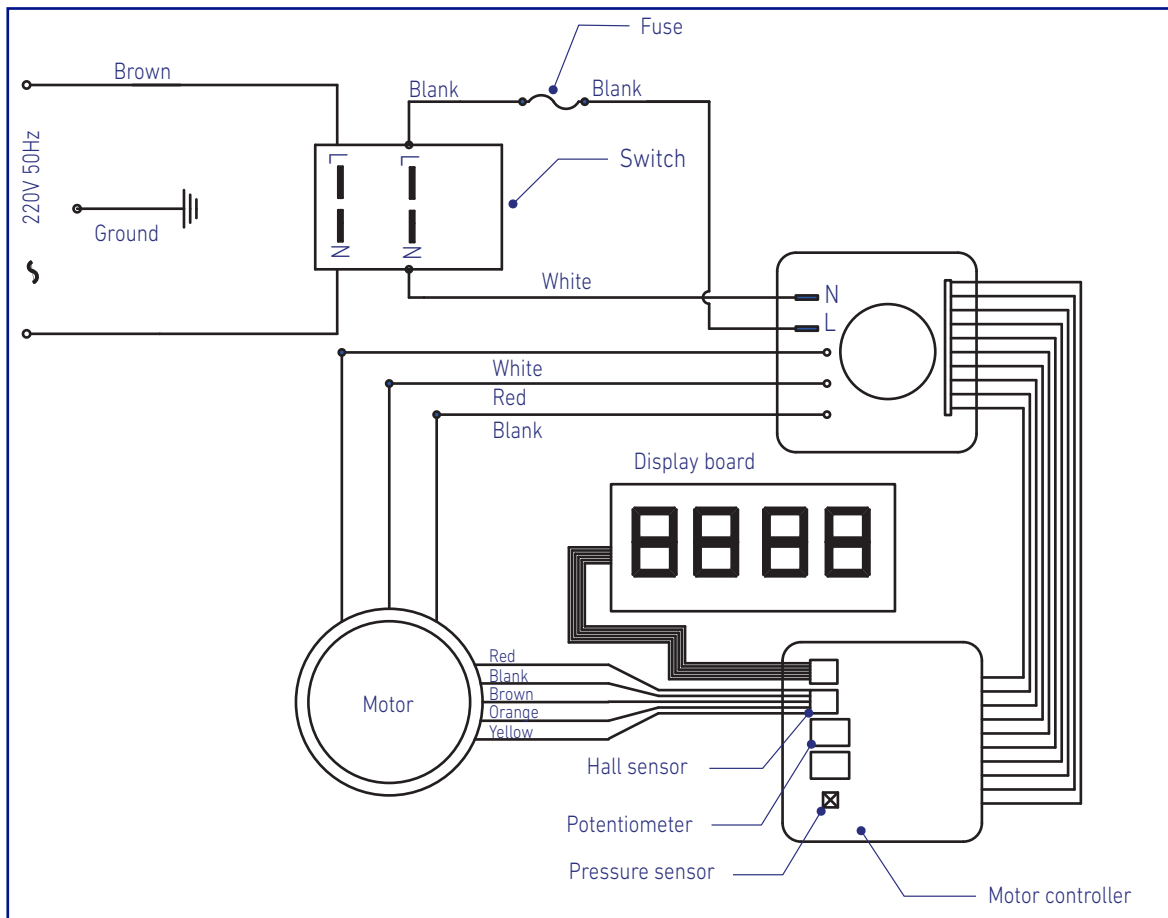

9. PARTS AND ASSEMBLY

Please examine the following diagrams carefully.

Cover Sets

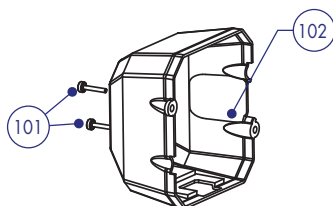

Driver Sets

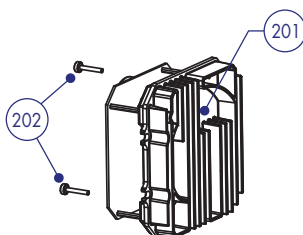

Baffle

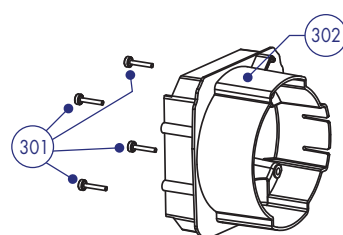

Motor

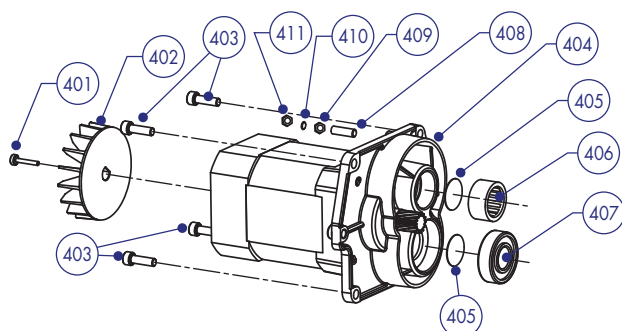

Gear

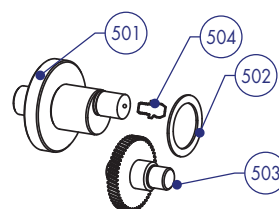

NO.	NAME	QUANTITY
101	Screw	2
102	Electric motor cover	1
201	Electric control assembly	1
202	Screw	2
301	Screw	4
302	Baffle	1
401	Screw	1
402	Fan	1
403	Screw	4
404	Motor	1
405	Shim ring	2

NO.	NAME	QUANTITY
406	Needle bearing	1
407	Ball bearing	1
408	Screw	1
409	Nut	1
410	Nut	1
411	Nut	1
501	Primary crankshaft	1
502	Seat	1
503	Secondary crankshaft	1
504	Glib	1

Housing

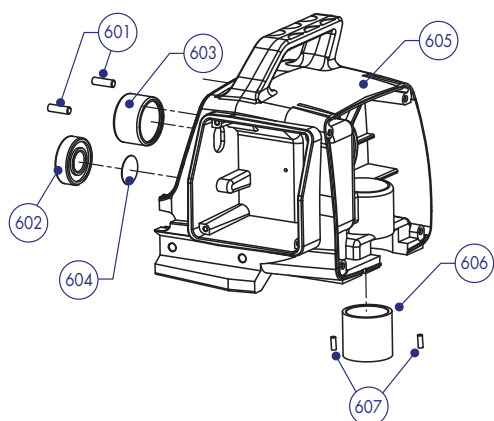

NO.	NAME	QUANTITY
601	Pin	2
602	Ball bearing	1
603	Needle bearing	1
604	Shim ring	1
605	Housing cover	1
606	Bushing cap	1
607	Pin	2

Belly Pan

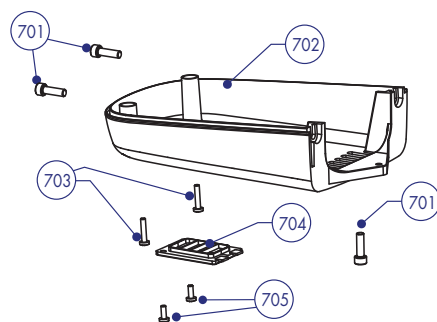

NO.	NAME	QUANTITY
701	Screw	3
702	Belly pan cover	1
703	Screw	2
704	Belly pan bottom cover	1
705	Screw	2

Slider Set

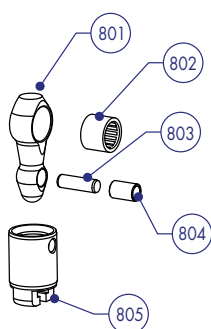

NO.	NAME	QUANTITY
801	Slider	1
802	Needle bearing	1
803	Pin	1
804	Bushing cap	1
805	T-slot	1

Motor Shroud Set

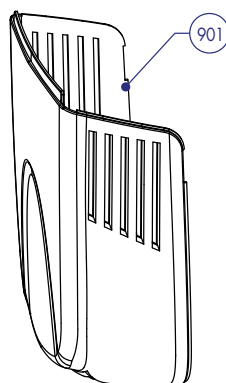

NO.	NAME	QUANTITY
901	Electric motor shroud	1

Face Plate Set

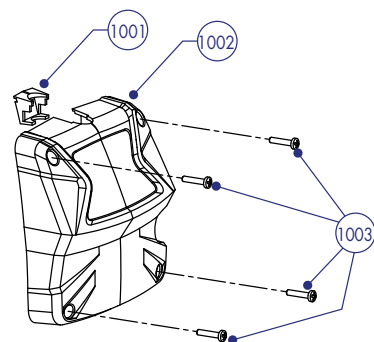

NO.	NAME	QUANTITY
1001	Cap	1
1002	Electric motor face plate	1
1003	Screw	4

Control Panel

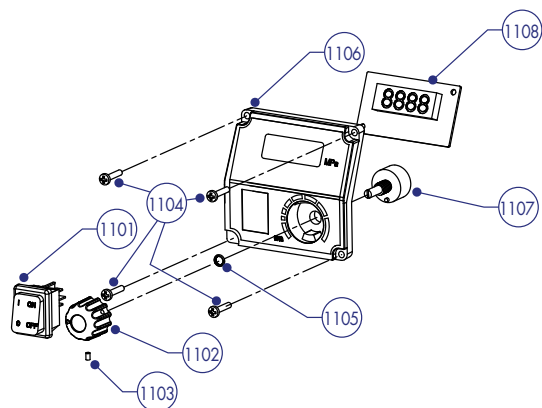

NO.	NAME	QUANTITY
1101	Switch	1
1102	Knob	1
1103	Screw	1
1104	Screw	4
1105	Nut	1
1106	Control panel cover with label	1
1107	Potentiometer	1
1108	Display	1

Oiler Set

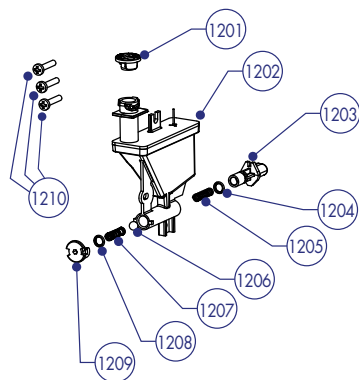

NO.	NAME	QUANTITY
1201	Oil cap	1
1202	Oil cup	1
1203	Button	1
1204	O-ring	1
1205	Spring	1
1206	Ball	1
1207	Spring	1
1208	O-ring	1
1209	Clip	1
1210	Screw	3

Leg Sets

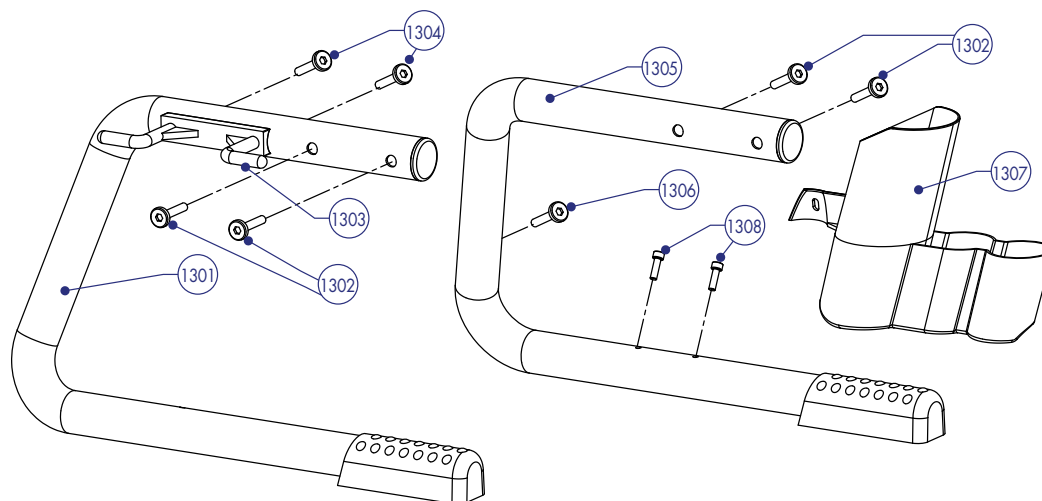

NO.	NAME	QUANTITY
1301	Left leg frame	1
1302	Screw	4
1303	Power cord holder	1
1304	Screw	2

NO.	NAME	QUANTITY
1305	Right leg frame	1
1306	Screw	1
1307	Drip cup	1
1308	Screw	2

Pump Group

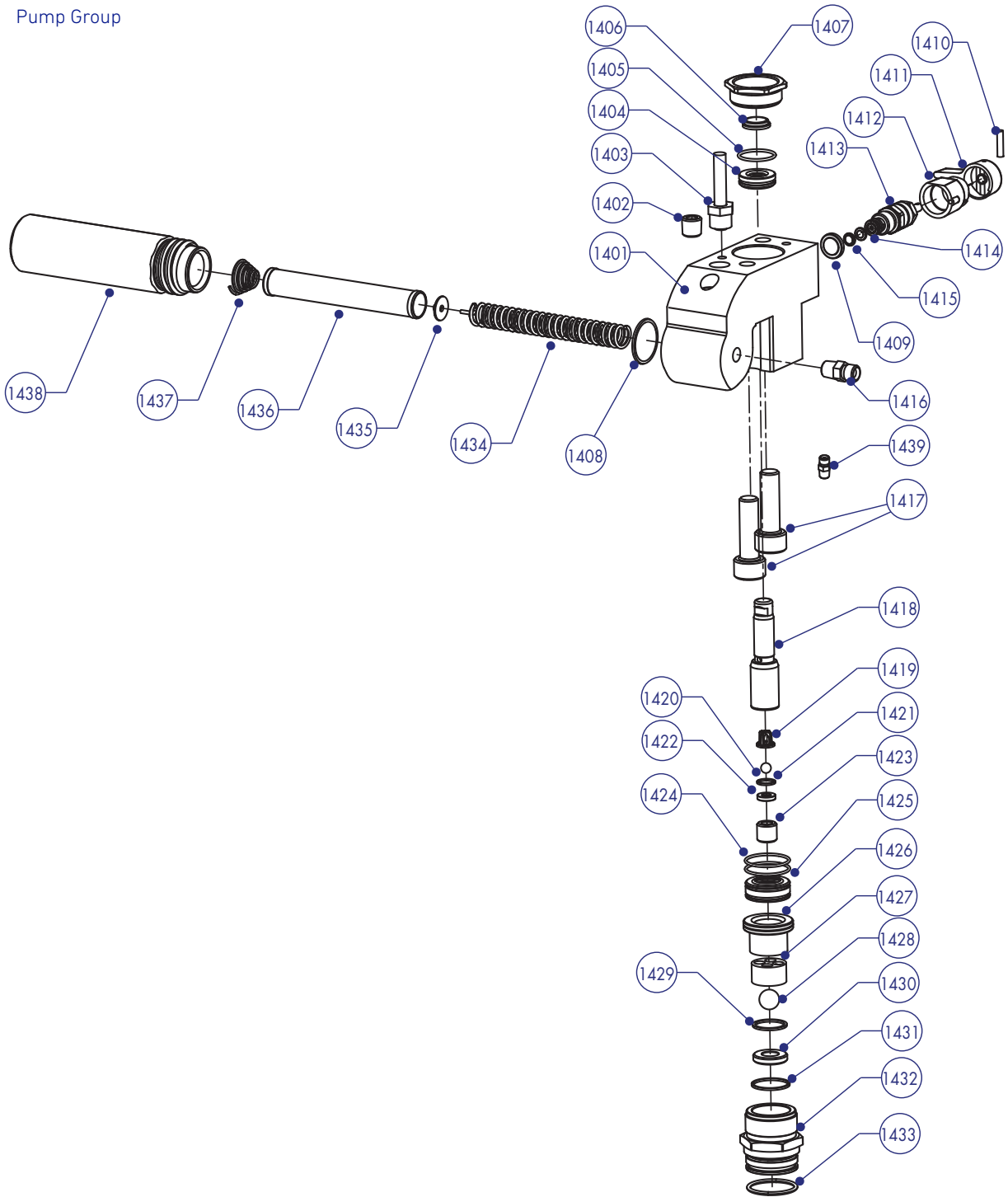

NO.	NAME	QUANTITY
1401	Pump assembly	1
1402	Pipe plug	1
1403	Transducer	1
1404	Upper packing	1
1405	O-ring	1
1406	Piston guide	1
1407	Retainer	1
1408	O-ring	1
1409	Gasket	1
1410	Gasket pin	1
1411	Relief valve knob	1
1412	Cam base	1
1413	Bypass valve	1
1414	O-ring	1
1415	O-ring	1
1416	Pump fitting	1
1417	Screw	2
1418	Piston rod	1
1419	Upper cage	1
1420	Outlet valve ball	1
1421	Gasket	1
1422	Outlet valve seat	1
1423	Outlet valve retainer	1
1424	O-ring	1
1425	Lower packing	1
1426	Bushing	1
1427	Lower ball guide	1
1428	Inlet valve ball	1
1429	Gasket	1
1430	Inlet valve seat	1
1431	O-ring	1
1432	Inlet valve seat	1
1433	O-ring	1
1434	Bearing spring	1
1435	Bearing ring	1
1436	Filter cartridge	1
1437	Conical spring	1
1438	Filter housing	1
1439	Return tube fitting	1

Siphon Assembly

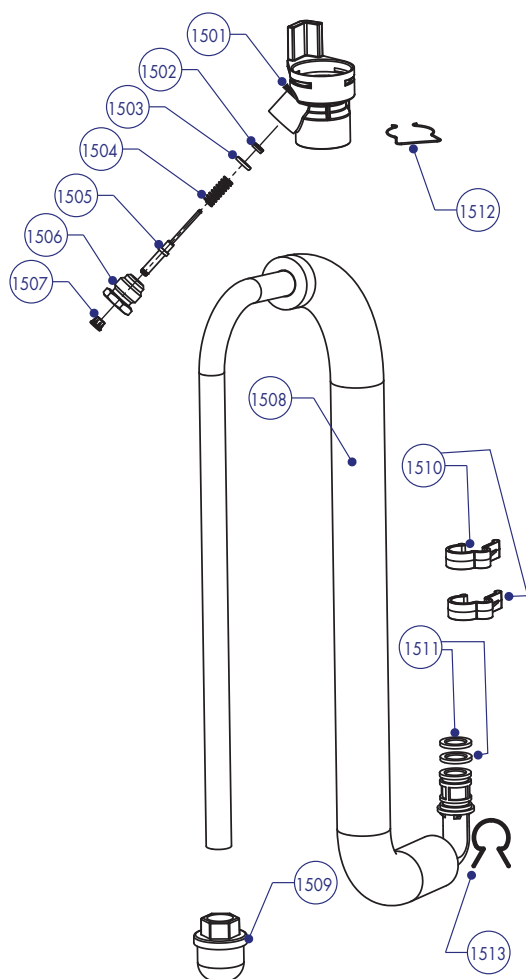

Fluid Return

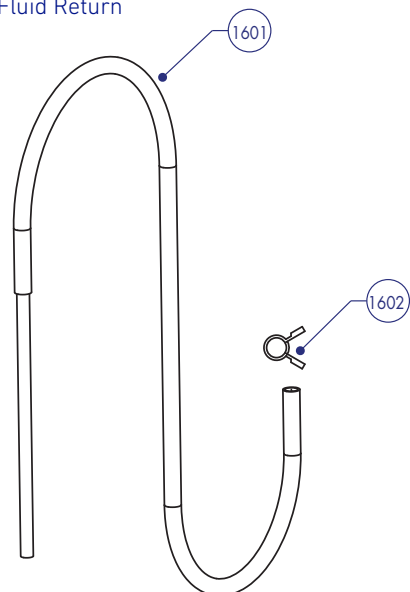

Power Cord Group

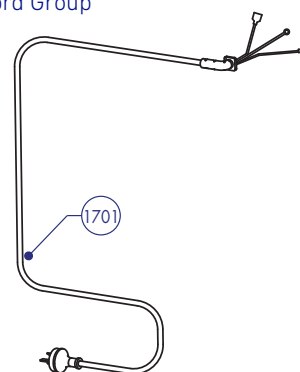

NO.	NAME	QUANTITY
1501	Siphon push assembly	1
1502	O-ring	1
1503	Locating pin	1
1504	Spring guide	1
1505	Siphon push rod	1
1506	Siphon push nut	1
1507	Pressure stem	1
1508	Suction hose	1
1509	Suction filter	1
1510	Clip	2
1511	O-ring	2
1512	Siphon push ring	1
1513	Suction hose clip	1
1601	Return hose	1
1602	Return hose clip	1
1701	Power cord	1

APPLICABLE FOR S21 HI-BOY ONLY

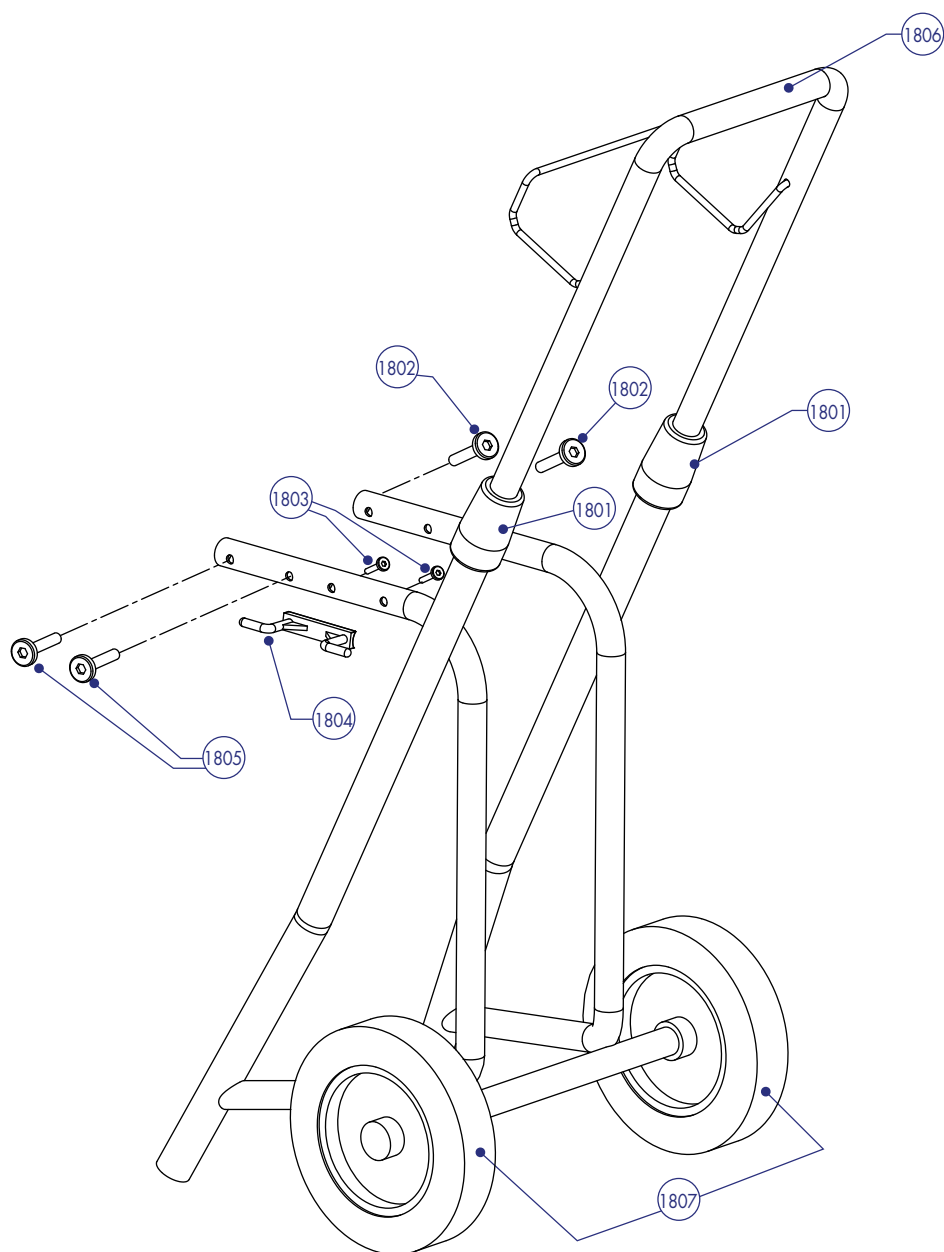

NO.	NAME	QUANTITY
1801	Adjustable stand knob	2
1802	Screw	2
1803	Screw	2
1804	Power cord holder	1
1805	Screw	2
1806	Trolley frame	1
1807	Pneumatic tyre	2

SELLEYS®

IF IT'S SELLEYS IT WORKS™

A Trusted Australian Brand Since 1939

Selleys is a subsidiary of
Nippon Paint (Singapore) Co. Pte Ltd
1 First Lok Yang Road, Jurong, Singapore 629728
Tel: 6265 5355 (Main Line)
www.selleys.com.sg